



4-20mA OUTPUT CURRENT SENSOR SERIES

Installation & Operation Instructions

Phone: 1-888-967-5224
Website: workaci.com

PRECAUTIONS

- This product is not intended to be used for Life or Safety applications.
- This product is not intended for use in any hazardous or classified locations.
- The A/CTA2 and A/SCTA2 Series Current Sensors must be used on Insulated Conductors Only.

HIGH VOLTAGE

- Disconnect and lock out all power sources before installation as severe injury or death may result from electrical shock due to contact with high voltage wires.

GENERAL INFORMATION

The 4-20 mA Output Analog Current Sensors are designed for use in any AC current monitoring application in which you are looking to monitor a particular piece of equipment. Applications may include monitoring a resistive type load such as an incandescent light bulb, heating element as well as any single speed linear load. For currents monitored above 250 Amps, the CTA2-5 and SCTA2-5 are ideal for use with a step down Ratio:5A Output CT (Current Transformer) in stepping down current in a monitored conductor to a proportional 0 to 5A output signal. The current sensors are available in both solid and split-core versions which also includes a Patented (Pat. No. US 7,416,421) 35 mm Din Rail mounting foot for easy installation in panel mount applications. The solid-core versions are a great choice for new installations or OEM applications in which cost sensitivity, lower trip points and environmental issues like dust and moisture may be of concern. The split-core version of the current sensors work great in retrofit applications and for use on service technicians vehicles since one or two parts will work in most applications and can be easily installed without disconnecting any wires.

INSTALLATION

Make sure that all installations are in compliance with all national and local electrical codes. Only qualified individuals that are familiar with codes, standards, and proper safety procedures for high-voltage installations should attempt installation. The current sensor is a 2-wire, 4 to 20 mA Loop Powered device

FIGURE 1: DIMENSIONS

Solid-Core

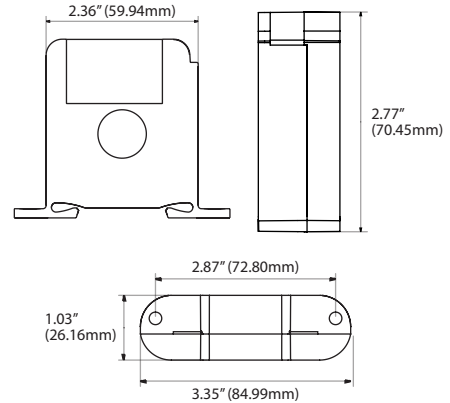

Split-Core

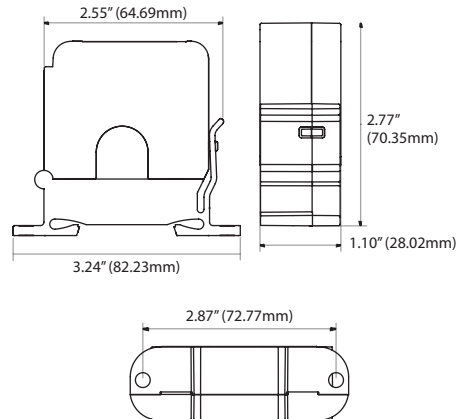

that requires a regulated +13.5 to 30VDC external power source.

The current sensor may be mounted in any position using the two #8 x 3/4" Tek screws and the mounting holes in the base, or snapped directly on to the 35mm DIN rail (See **Figure 3**). Leave a minimum distance of 1" (3 cm) between the current sensor and any other magnetic devices such as contactors and transformers.

Latch Operation for A/SCTA2 Series

Press down on the side tab and swing the top of the unit up to open the split core current sensor as shown in **Figure 2**. Press down firmly on the cover to close the current sensor. An audible "click" will be heard as the tab slides over the tongue on the base.

CAUTION: Mating surfaces of the magnetic core are exposed when the sensor is open. Electrical contact grease, present on the cores to prevent corrosion, can capture grit and dirt if care is not exercised. Operation can be impaired if anything prevents good contact between pole pieces. Visually check the mating parts of the core before closing the current sensor.

Current Sensor Setup

The amperage range selected represents the maximum current that can be applied to the conductor being monitored. Do not exceed! All current sensors with selectable ranges will have the range selection jumper factory set on the high range. For models with field selectable amperage ranges, select the correct amperage range using the range selection jumper. Note that all -RMS models have True RMS outputs and should be used with Variable Frequency Drives.

Note: An extra jumper shunt is included. It can be discarded if not needed.

Note: In applications where high vibrations are encountered, ACI recommends to use the jumper shunt without tab. A pliers can help with jumper shunt installation onto the pins.

FIGURE 2: OPENING A/SCTA2 SERIES

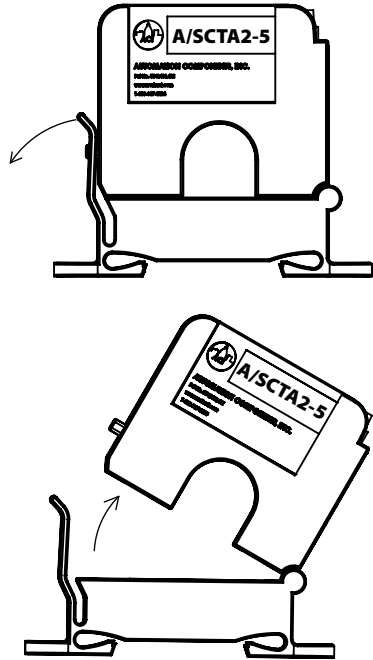

FIGURE 3: DIN RAIL INSTALLATION

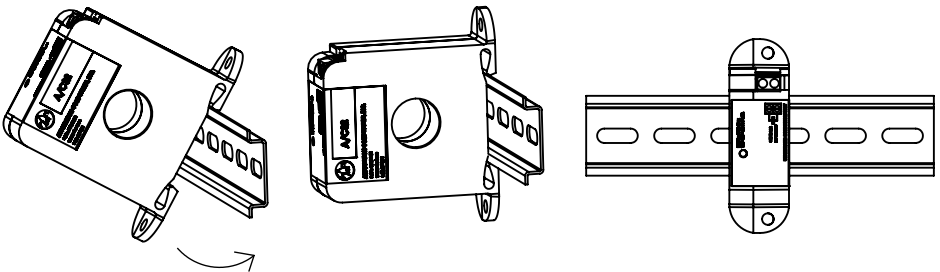
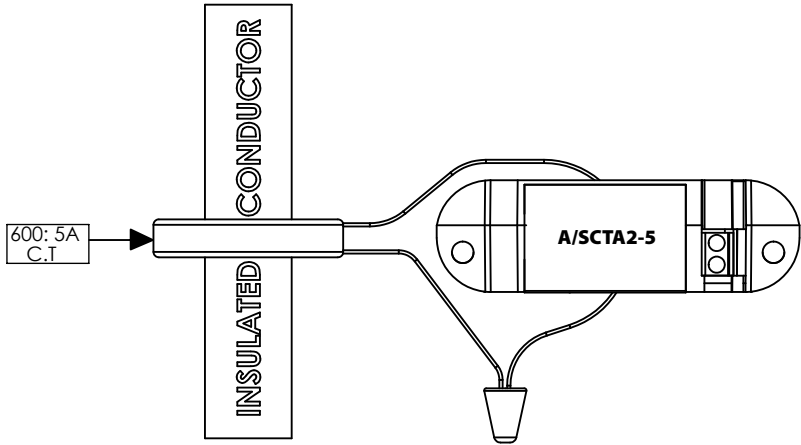

FIGURE 4: CURRENT TRANSFORMER



APPLICATION NOTES

For load currents greater than sensor maximum continuous current rating:

For applications in which the normal operating current is greater than 250 Amps or for conductors larger than 0.750" (1.90 cm) in diameter, an external 5 Amp Current Transformer must be used as shown in **Figure 4**. Use the A/CTA2-5 or A/SCTA2-5 to scale the 5A current to a 4-20ma current.

WIRING INSTRUCTIONS

ACI recommends the use of a two conductor 16 to 22 AWG shielded cable, copper wire only, for all 4 to 20mA current sensor installations. A maximum wire length of less than 30 meters (98.4 feet) should be used between the current sensors and the Building Management System or controller. All wiring must comply with all local and National Electric Codes.

Note: When using a shielded cable, be sure to connect only (1) end of the shield to ground at the controller. Connecting both ends of the shield to ground may cause a ground loop.

When removing the shield from the sensor end, make sure to properly trim the shield to prevent any chance of shorting. The current sensor terminals are polarity sensitive and represent a linear and proportional 4 to 20mA output signal. Tighten the screws at the terminal block connections to the recommended torque of 0.5 to 0.6 Nm (4.43 to 5.31 in-lbs.). The aperture (hole) size of the current sensor is 0.75" (1.90 cm).

FIGURE 6: ANALOG CIRCUIT

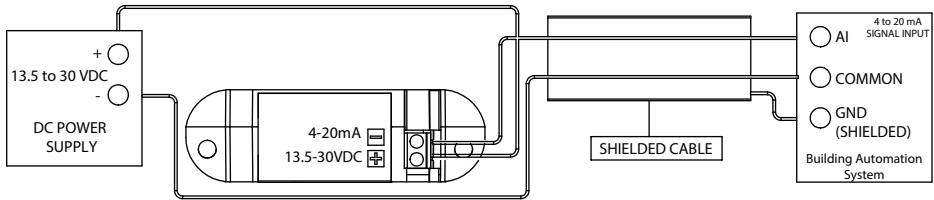

TROUBLESHOOTING

PROBLEM	SOLUTION(S)
No reading	<ul style="list-style-type: none"> - Confirm that you have +13.5 to 30VDC in series with the current sensor output terminals and the analog input of the control panel. - Check the polarity of the circuit. - Verify that the terminals are screwed down, wires are firmly in place. - Disconnect the input to the control panel and then insert a current meter (mA range) in series with the current sensor output to verify that the circuit is working properly.
Erratic readings	<ul style="list-style-type: none"> - Verify that the wires are terminated properly. - Check that the +13.5 to 30VDC input is clean. In areas of high RF interference, shielded cable may be necessary to stabilize signal.
Inaccurate readings	<ul style="list-style-type: none"> - If you suspect that the current sensor is not reading within the accuracy specifications, please contact the factory for assistance.
Current Sensor is operating at a low-level current or failing to operate within the accuracy specifications.	<ul style="list-style-type: none"> -Visually check the mating parts of the core to ensure there is no debris between the split contacts. See Figure 2. -Remove all debris or dust manually and close the current sensor. -Continue to retest the sensor in your application.

STANDARD ORDERING

Model #	Item #	Selectable Ranges	Measurement	AC Waveform	Solid-Core	Split-Core	Output Signal
A/CTA2-5	142379	0 to 5A	Average	Pure Sinusoidal	•		4 to 20 mA
A/CTA2-50	142378	0 to 10/20/50A	Average	Pure Sinusoidal	•		4 to 20 mA
A/CTA2-250	142377	0 to 100/200/250A	Average	Pure Sinusoidal	•		4 to 20 mA
A/SCTA2-5	142376	0 to 5A	Average	Pure Sinusoidal		•	4 to 20 mA
A/SCTA2-50	142375	0 to 10/20/50A	Average	Pure Sinusoidal		•	4 to 20 mA
A/SCTA2-200	142374	0 to 100/150/200A	Average	Pure Sinusoidal		•	4 to 20 mA
A/CTA2-50-RMS	142373	0 to 10/20/50A	True RMS	Distorted & Pure Sinusoidal	•		4 to 20 mA
A/CTA2-250-RMS	142372	0 to 100*/200/250A	True RMS	Distorted & Pure Sinusoidal	•		4 to 20 mA
A/SCTA2-50-RMS	142371	0 to 10/20/50A	True RMS	Distorted & Pure Sinusoidal		•	4 to 20 mA

Note*: Only the 100 Amp Range will meet the accuracies over the operating frequency range of 15 to 100 Hz (See Specification Table)



PRODUCT SPECIFICATIONS

SENSOR NON-SPECIFIC INFORMATION	
Monitored Current Type:	AC Current
Maximum AC Voltage:	600 VAC
Isolation Voltage:	2200 VAC
Operating Frequency Range ²:	A/CTA2 & A/SCTA2 Series: 40 to 1KHz A/CTA2-50-RMS & A/SCTA2-50 RMS: 15 to 100 Hz A/CTA2-250-RMS (0-100A Range): 15 to 100 Hz A/CTA2-250-RMS (0-200/250A Ranges): 30 to 100 Hz
Core Style:	Solid-Core and Split-Core Versions available (See Ordering Grid pg. 5)
Supply Voltage:	+8.5 to 30 VDC (Reverse Polarity Protected) 250 Ohm Load (1-5 VDC): +13.5 to 30 VDC 500 Ohm Load (2-10 VDC): +18.5 to 30 VDC
Maximum Load Resistance @ 24 VDC:	775 Ohms (Formula: (24 VDC – 8.5 VDC) / 0.020A)
Supply Current:	25 mA minimum
Sensor Amperage Range:	See Ordering Grid pg. 5 (Field Selectable)
Output Signal Maximum Output Signal:	4 to 20 mA (2-Wire, Loop Powered) Limited to 25 mA
Accuracy ¹:	All Models: +/- 1% of Selected Range except A/SCTA2-50-RMS: +/- 2% from 15 to 20 Hz +/- 1% from 20 to 100 Hz
Response Time:	A/CTA2-xxx and A/SCTA2-XXX: < 600 mS (Rise and Fall Time) A/CTA2-xxx-RMS & A/SCTA2-50-RMS: 600 mS (Rise Time) and 2800 mS (Fall Time)
Aperture Size:	0.75" (19.05 mm)
Din Rail Size:	35 mm (U.S. Patent No. 7,416,421)
Operating Temperature Range:	5 to 104°F (-15 to 40°C)
Operating Humidity Range:	0 to 95%, non-condensing
Storage Temperature RH Range:	41 to 95°F (5 to 35°C) 40% to 85% RH, non-condensing
Enclosure Material Flammability Rating:	PC/ABS (Polycarbonate/ABS Blend) UL94-V0
Wiring Connections:	2 Position, Screw Terminal Block (Polarity Sensitive)
Wire Recommendations:	2 Conductor (Shielded Cable)
Wire Size:	18 to 24 AWG (0.823 mm ² to 0.205 mm ²) Copper Wires only
Terminal Block Torque Rating:	4.43 to 5.31 in-lbs. (0.5 to 0.6 Nm)
Minimum Mounting Distance:	1" (2.6 cm) between current sensor & other magnetic devices (Relays, Contactors, Transformers)

Note¹: All current output sensors are calibrated at an ambient room temperature of 71°F (21.5°C) |

Note²: Only the 0 to 100 Amp range in the A/CTA2-250-RMS will meet accuracy specifications from 15 to 100 Hz

WARRANTY

The ACI Current Switch Series are covered by ACI's Five (5) Year Limited Warranty, which is located in the front of ACI'S SENSORS & TRANSMITTERS CATALOG or can be found on ACI's website: www.workaci.com.

W.E.E.E. DIRECTIVE

At the end of their useful life the packaging and product should be disposed of via a suitable recycling centre. Do not dispose of with household waste. Do not burn.



NOTES

NOTES



NOTES

NOTES



NOTES



Automation Components, Inc.

2305 Pleasant View Road
Middleton, WI 53562

Phone: 1-888-967-5224

Website: workaci.com

